

**Rugged lasers
for industrial
pre-alignment
applications**

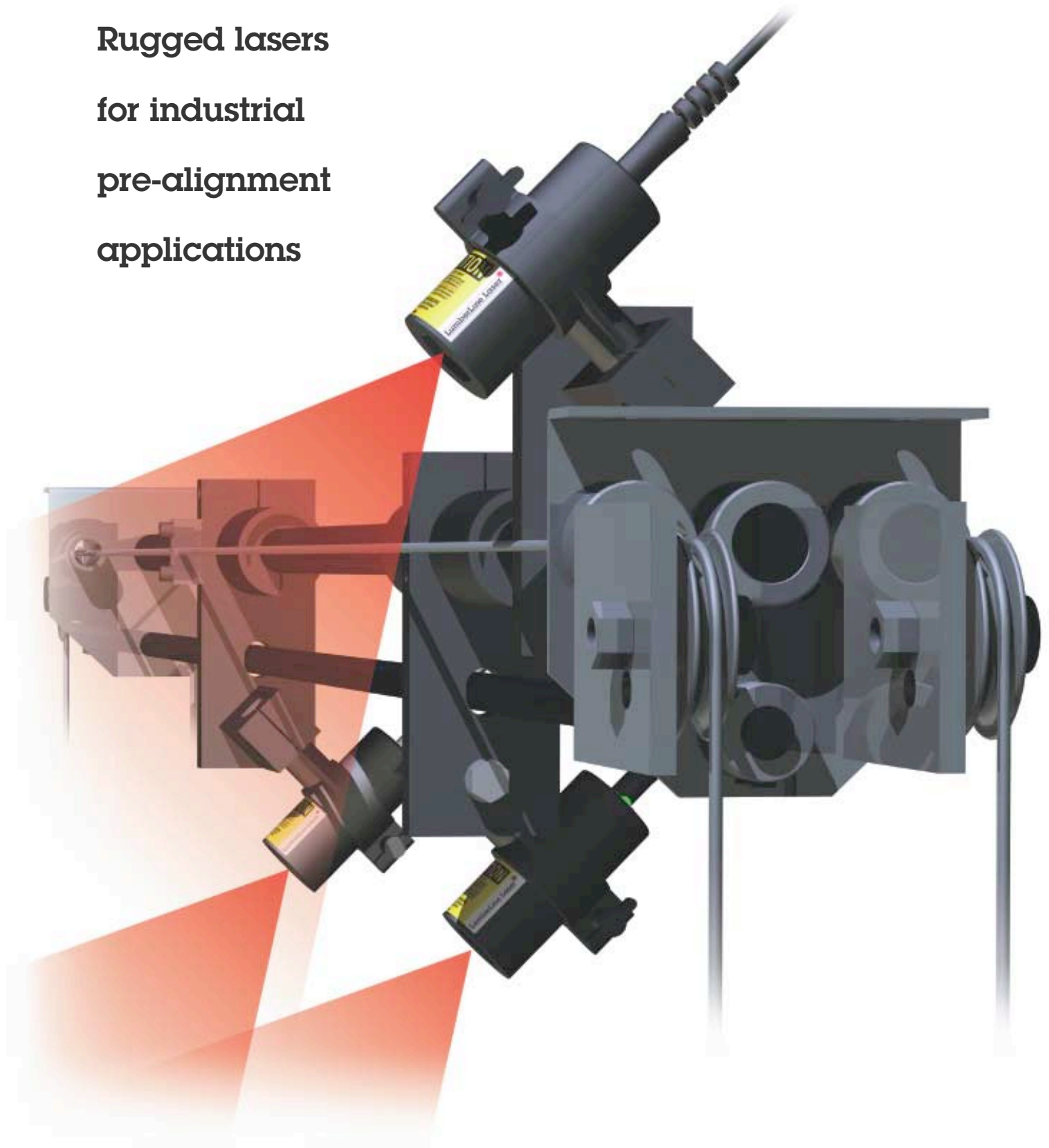

LumberLine Laser 

LumberLine Laser



Laser pre-alignment of rough timber before sawing greatly minimizes wasted wood, maximizing efficient material processing.

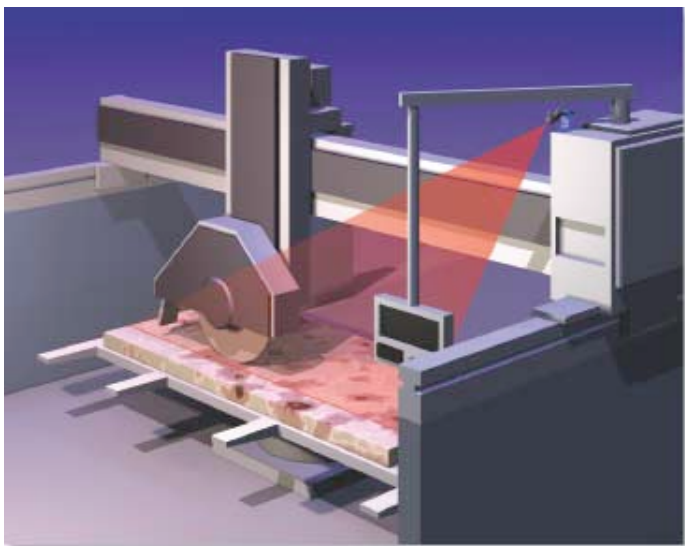

Laser pre-alignment of marble before sawing eliminates bad cuts that wastes valuable material and time.

Lumberline Laser has served industry since 1985 by producing reliable laser products that increase productivity and lower operating cost. Applications include the lumber industry, producers of architectural marble, metal fabricators, and any other application where visual pre-alignment for material processing is required. We have engineered our rugged products based on extensive field testing. They feature long service life, quality materials, ease of installation and quick adjustment, with the minimum of maintenance. Our lasers are manufactured in the U.S.

What's in this catalog:

| | |
|--|---|
| Available Lasers..... | 3 |
| Shift Assembly..... | 4 |
| Independent Shift Subassemblies | 5 |
| <i>Slider Assemblies and Parts</i> | |
| <i>Stationary Shift Assembly Bracket</i> | |
| Laser assemblies for multiple rip saws | 6 |
| Mounting fixtures..... | 7 |
| <i>Stationary Mounting Bracket</i> | |
| <i>3" Handset Slider for Rip Saws</i> | |
| Ordering, shipping and warranty..... | 8 |

End Projection lasers

Lumberline's innovative, rugged lasers are designed for superior performance in the most demanding industrial applications.

Lumberline's Lasers Feature:

- **Bright laser output**
- **Vibration resistant**
- **Long life**
- **Compact design**
- **On light indicator**
- **Cord strain relief**

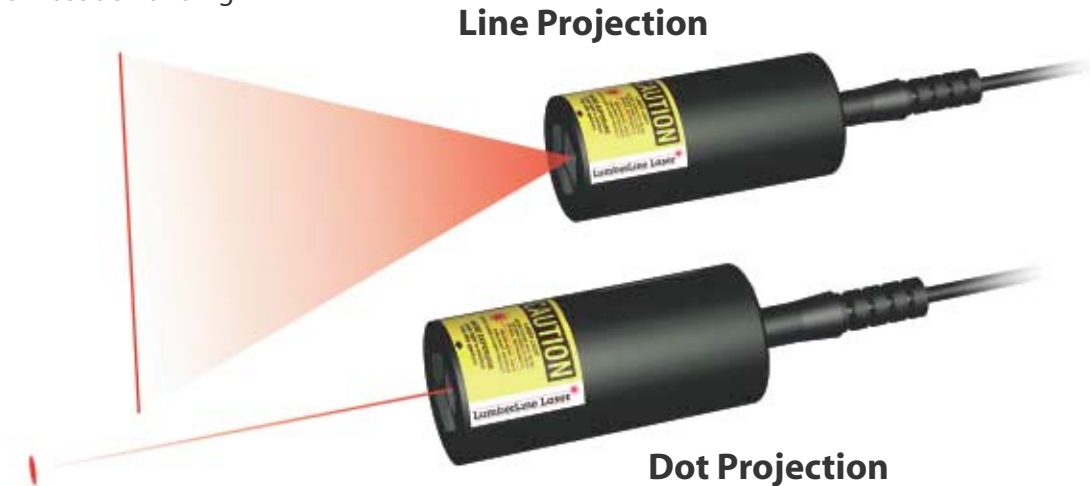

End Projection Laser Specifications

Dimensions: Length: 3.00"
Diameter: 1.25"
Power Cord: Length 9.5 ft.
Voltage: 100-240 vac (with standard power supply, part #SA-115)
12-24 vdc (with voltage converter, part #SA-117)

Laser Source: Solid State
Models: L-05/5 milliwatt (up to 6' line*)
L-10/10 milliwatt (up to 16' line*)
L-20/20 milliwatt (16' and over*)
Weight: 2.3 oz
Environment: NEMA 12 rating
Options: TTL enable/disable with control box, part #SA-116
Warranty: 24 month limited warranty (see back cover)

Circle Projection laser

Lumberline's circle projection lasers are constructed with the same rugged design as our end projection lasers. They feature an adjustable diameter circle up to 120° projection, with a center spot.

Lumberline's Circle Projection Laser Features:

- **Bright laser output**
- **Vibration resistant**
- **Long life**
- **Compact design**
- **On light indicator**
- **External power supply**
- **Mounting bracket available**

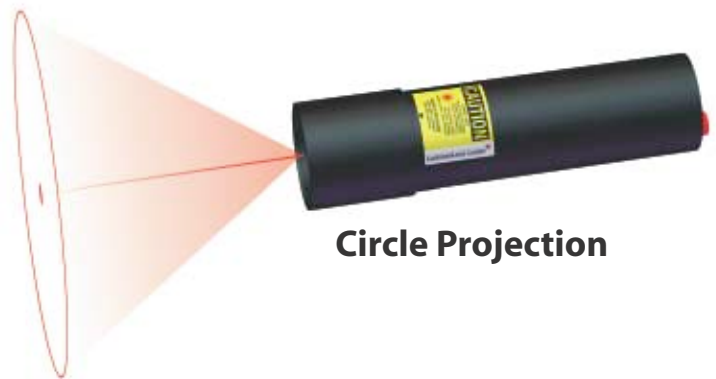

Circle Projection Laser Specifications

Dimensions: Length: 6.5"
Diameter: 2.0"
Power Cord: Length 9.5 ft.
Voltage: 100-240vac
Laser Source: Solid State
Models: L-20-Circle/20 milliwatt (16' and over*)
Weight: 1.0 lb.
Environment: NEMA 12 rating
Warranty: 24 month limited warranty (see back cover)

Shift Assembly

Independent Shift Assembly for horizontal or vertical machines

Model SA-001

2-saw Unison Shift Assembly shown in horizontal configuration



Model SA-002

2-saw independent Shift Assembly shown in horizontal configuration

LumberLine's Shift Assemblies track lasers as saws are moved, or provide a stable mounting platform for easily adjustable stationary laser applications. They are available in 2-Saw Independent, 2-Saw Unison, and 1-Saw Moveable/1-Saw Stationary configurations.

Lumberline Laser's Shift Assemblies Features:

- **Rugged 3/4" nitro steel shafts maintains alignment and repeatability**
- **Delrin bushings for long life and low friction**
- **Steel cable sheaves**
- **Machined 6061 anodized aluminum components**
- **1/8" aircraft cable included**
- **Comes completely assembled including mounting brackets for lasers (lasers not included)**
- **Shaft lengths available in increments of 1' up to 72"**
- **Sheaves swivel for easy cable routing**
- **Additional stationary brackets available (see page 7)**
- **Works for horizontal or vertical edgers**
- **Shift assembly is adaptable to changes in saw configurations**
- **Can be adjusted to less than 3" between laser lines**



Independent Shift Subassemblies

Slider Assemblies and Parts



Stationary Shift Assembly

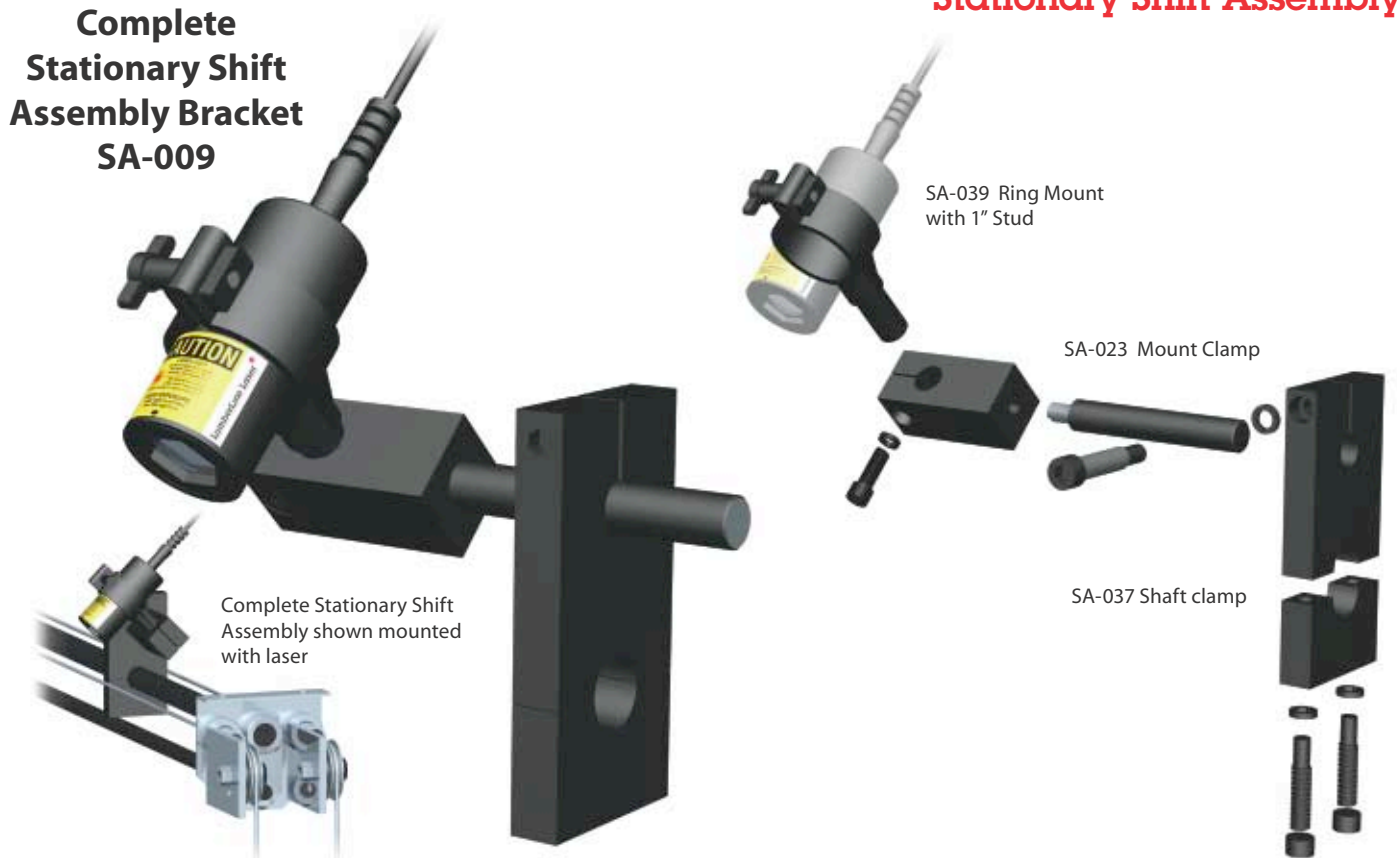

Laser Assembly for Multiple Rip Saws

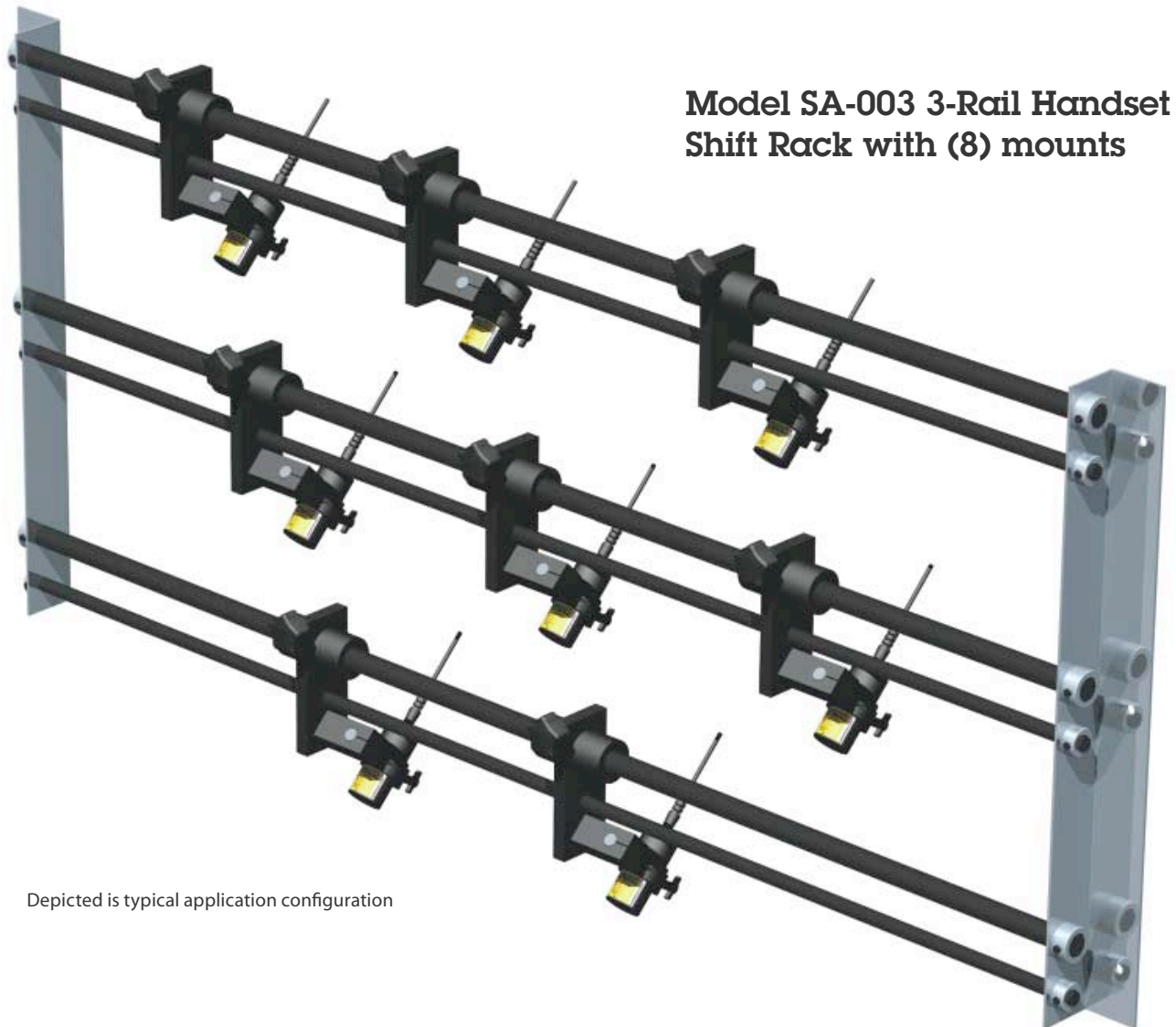

**Model SA-003 3-Rail Handset
Shift Rack with (8) mounts**

Depicted is typical application configuration

LumberLine's Laser Assembly for Multiple Rip Saws illuminates each individual saw cut, and is easily adjustable for changing saw spacing. Accurate repeatability maintains alignment to saw vertical and horizontal planes, and can be adjusted to accommodate very narrow spacing. Side rails are 22" long. Available with 3 shafts standard.

Lumberline Laser's Assembly for Multiple Rip Saws Features:

- **Rugged 3/4" nitro steel shafts maintains alignment and repeatability**
- **Delrin bushings for long life and low friction**
- **Machined 6061 anodized aluminum components**
- **Quick adjustment, hand-tightening locking knobs**
- **Comes completely assembled including mounting brackets for lasers (lasers not included)**
- **Shaft lengths available in increments of 1' up to 72"**
- **Additional stationary brackets available (see page 9)**



Mounting Fixtures

Stationary Mounting Bracket

Stationary Mounting Bracket Assembly SA-008



3" Handset Slider for Rip Saws

SA-065 Handset Trolley Knob

SA-027 3/4" Delrin Bearing (2)
SA-064 Snap Ring (2)

SA-032 3" Trolley Tube

SA-020 Trolley Clamp

SA-023 Mount Clamp

3" Handset Slider Assembly SA-011

SA-039 Ring Mount with 1" Stud



Ordering, Shipping and Warranty

Ordering

To order: Call LumberLine Laser between 8 A.M. and 5 P.M., Monday through Friday, PST.

Credit Card Orders: LumberLine Laser accepts MasterCard and Visa.

Phone: 360-686-3077 • **Fax:** 360-686-3033

www.lumberlinelaser.com • **email:** mail@lumberlinelaser.com



Warranty

Lumberline Laser warrants products to be free of material defects for 24 months from date of purchase. Should warranty replacement or repair be required, call LumberLine Laser for a required return merchandise authorization number (RMA) prior to shipping product. Customer pays shipping of product to LumberLine Laser. We will replace or repair the defective product and pay return shipping.

Unauthorized modification, disassembly, accidental or willful damage, acts of God, or damaged manufacturer serial number and date label on laser voids warranty.

Terms and Conditions

Prices:

All prices are subject to change without notice. We cannot control price increases by our suppliers. We also reserve the right to correct misprints.

Open Account Billing Terms:

To open an account, please provide us with bank reference and account number, and two trade references.

Purchase Orders:

Please provide us with a Purchase Order Number. Your issuance of a purchase order will be deemed to be an assent to these terms and to any terms contained in any quotation we provide or have provided you. They supersede any inconsistent provisions contained on your purchase order.

Shipping:

Unless merchant and customer specifically agree otherwise in writing, all shipments are made F.O.B. Yacolt, WA, USA, using packaging and shipping methods selected by us. There are additional charges for express shipping. You understand that any date of delivery is only an estimate and we will have no liability for late or partial deliveries. We may refuse to fulfill any order for any reason. We have no responsibility for loss or damage to the goods after we have delivered them to any common carrier.

Warranty Return Policy:

All returned merchandise subject to inspection and approval by Lumberline Laser before issuing credit or replacement. Merchandise displaying misuse or damage will not be accepted. Items must be in original manufacturer's packaging. Product should be packaged in a separate carton with the return merchandise authorization number (RMA) clearly marked on this shipping carton.



Laser Warning Poster

- Keep OSHA compliant with this available 8.5 x 11 poster

LumberLine Laser

26407 NE 356th St.

Yacolt, WA 98675

tel: 360-686-3077

fax: 360-686-3033

www.lumberlinelaser.com